

MAGNETIC SENSOR

MP1013 Series



Hall-effect proximity sensor with convenient snap-fit mounting.

Features

- Solid state reliability
- Excellent output stability over operating temperature range
- Regulated power supply not required
- Meets IEC529 IP67 for dust and water protection
- Open Collector (NPN) output can be used with bipolar switch or CMOS logic circuits with suitable pull up resistor
- MP101301 and MP101302 — unipolar switch
 - Output switches high (on) when the magnetic field is reduced to below the release point threshold
- MP101303 — bipolar latch
 - Output latches high (on) in the presence of a south pole
 - Output unlatches (low or off) in the presence of a north pole

Applications

- Speed sensing
- Door interlock sensing
- Water flow sensing

Specifications

Part Number	Operating Voltage Range (VDC)	Supply Current (mA max.)	Output	Output Saturation Voltage (mV max.)	Output Current (mA max.)	Operating Temp Range (°C)	Storage Temp Range (°C)	Operate Point Gauss (max.)	Release Point Gauss (min.)	Leads	Reverse Battery Protection
MP101301	4.75 – 24	9	3-wire sink	400	25	-40 to 85	-40 to 105	300	60	24 AWG x 150mm	-24VDC
MP101302	4.75 – 24	9	3-wire sink	400	25	-40 to 125	-40 to 125	300	60	24 AWG x 150mm	-24VDC
MP101303	3.5 – 24	4	3-wire sink	500	25	-40 to 85	-40 to 105	45	-45 (latch)	24 AWG x 150mm	None

Notes: These sensors require the use of an external pull-up resistor, the value of which is dependent on the supply voltage. See page 18 for recommendations. Pull-up resistor should be connected between output (Green) and Vcc (Red).

Dimensions inches (mm)

All tolerances ±0.005 (0.13) unless otherwise noted.

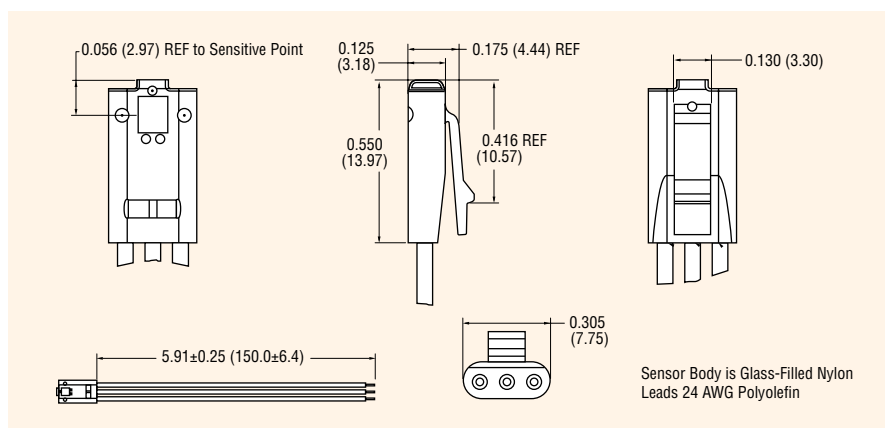

Open Collector Sinking Block Diagram

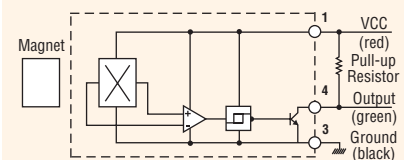

Sensor Pocket

